

Glass Condensate Traps



SGL - Scientific Glass Laboratories Ltd are the leading UK manufacturer of Borosilicate Glass Condensate Traps.

Since 1968, Borosilicate glass traps manufactured by SGL have been utilised in the Air Conditioning Industry and have found extensive use in hospitals, public buildings and industrial sites throughout the world. It has established itself as the ultimate system for the disposal of condensate waste.

- **Easy Visual Inspection**
- **Help Prevent Legionella**
- **Self-Cleaning, Smooth Non-Porous Surface**
- **UK's Leading Glass Condensate Trap Manufacturer**

Providing Scientific Glassware to Laboratories for over 40 years

**Scientific Glass
Laboratories Ltd**

t. 01782 816237

f. 01782 575637

www.scientificglass.co.uk



INTRODUCTION

SGL are the leading U.K. manufacturer of borosilicate glass drainage. For over a decade Borosilicate glass traps manufactured by SGL have been utilised in the Air Conditioning Industry and have found extensive use in hospitals, public buildings and industrial sites throughout the world. It has established itself as the ultimate system for the disposal of condensate waste.

The advantages of using SGL borosilicate glass condensate traps are :

- With universal resistance to corrosion, the glass - in conjunction with simple leak free couplings - provides the basis of a system which requires minimum maintenance and provides a long service life.
- The inert properties of the PTFE (polytetrafluoroethylene) lined couplings ensures that the integrity of the system is maintained.
- The glass is effectively self-cleaning. Smooth non-porous surfaces discourage fouling and in the exceptional circumstances of scale forming, this can be easily removed.
- Industry wide proven track record as the No. 1 system, and specified by all leading consulting engineers / architects.

GENERAL & TECHNICAL INFORMATION

Industry Standards

SGL glass drainage components are manufactured exclusively from borosilicate glass type 3.3 which complies in terms of physical, chemical and mechanical properties to ISO 3585 and BS 2589 part 1.

Type 3.3 borosilicate glass complies with Fire resistant test conditions of BS476 part 8. The glass components of the SGL drainage system will not burn or support combustion. Neither will they transmit fire nor give off noxious fumes when subjected to heat, no matter how intense.

Composition

SGL Borosilicate Glass

Component	% by weight
-----------	-------------

SiO ₂	80.6
B ₂ O ₃	12.5
Na ₂ O	4.2
Al ₂ O ₃	2.2
Others	0.5

SGL Couplings

The unique coupling system consists of a one-bolt stainless steel outer shell, a rubber elastomer inner with the unrivalled PTFE (polytetrafluoroethylene) seal. As only this part of couplings comes into contact with the condensate the integrity of the system is maintained, ensuring the reliability demanded by our clients.

Mechanical Properties

Compressive - 5000 lb/1N²

Tensile - 500 lb/1N²

Thermal Expansion - 0-300°C is $33 \times 10^{-6} \text{ K}^{-1}$

Permissible Operating Pressure

SGL condensate systems are designed to operate within the pressure range from full vacuum to 1 bar.g.

Installation / Maintenance

SGL condensate systems are quickly and easily installed. A simple one-bolt coupling is used to join components together and as no heat or adhesives are required, SGL condensate systems are more than often installed quicker than any other services. This also allows for dismantling of the system in the same way.

The unique combination of glass / PTFE seal provide visual inspection of the system for seal integrity, together with an unparalleled inert environment that actively discourages the build up of debris, thus maintenance is kept to a minimum.

THE CONTROL OF LEGIONELLOSIS

About Legionella

The first identified outbreak of legionnaires' disease occurred among people who had attended a Pennsylvania State Convention, in 1976. Respiratory examination concluded that a new bacterium now known as Legionella pneumophila was to blame.

Legionella although difficult to detect, seems to concentrate around specific areas, the most prevalent being that of stagnant water, and in particular man made water systems.

After the outbreak in Stafford in April 1985, and the subsequent, 1st and 2nd reports of the committee of enquiry chaired by Sir John Badenoch, recommended CH13 paragraph 283 and 284 that drains from air conditioning units should utilise glass traps to comply with HH (Hazard) 85/6 dated 9.7.85 clause 5.

Legislation

A suitable water treatment regime must be implemented to comply with:

- Health & Safety at Work Act 1974 sections 2,3 and 4, risks from legionella, in particular the Control of Substances hazardous to Health Regulations 1988 (COSHH).
- Health & Safety Doc HS(G)70 'The control of legionellosis'.
- Health & Safety Approved Code of Practice 'The prevention or control of legionellosis'.

(copies of which can be supplied on request).

Avoidance of Materials

As specified in Health & Safety recommendations HS(G)70 para 43, every attempt should be made to avoid the use of materials that harbour bacteria and other micro-organism, or provide nutrients for microbiological growth, these include:

1. Some rubbers
2. Jointing compounds and mastics
3. Wooden packing & certain plastics

And other materials as specified by the Water Research Centre (Water fittings & materials directory).

Prevention

SGL condensate traps were specifically designed for the prevention / control of legionella type diseases, they are now installed in a wide range of buildings throughout the world, and have a proven track record second to none. A typical set up of a plant drain should be as follows:

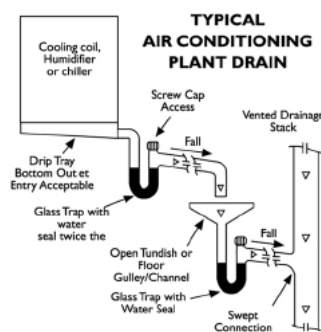

Inspection of the traps e.g. seal depths can be easily monitored due to the transparency of glass, dosing points allow for filling / cleaning.

The self-cleaning nature of these traps helps prevent colonisation of sediments such as rust, scale, sludge and algae from providing the nutrients that support the proliferation of legionella.

Recommendations

Biocidal treatment is an essential part of all water treatment regimes, SGL's unique inert combination of borosilicate glass / PTFE (polytetrafluoroethylene) sealed couplings perform safely with any temperature or biocidal fluctuations, integrity of the system is therefore assured.

(details available from our technical dept)

Scientific Glass Laboratories Ltd

t. 01782 816237 f. 01782 575637

Canal Lane, Tunstall, Stoke-on-Trent, Staffordshire ST6 4PQ

email. sales@scientificglass.co.uk www.scientificglass.co.uk

Traps & Fittings

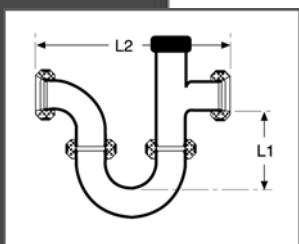

Running Trap - Horizontal Inlet / Outlet

DN	L	L1	L2	Code No.
20	205	110	190	TA20/1
25	230	120	210	TA25/1
40	270	125	290	TA40/1

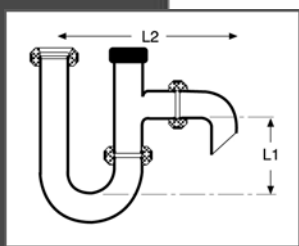

S Trap - Vertical Inlet / Horizontal Outlet

DN	L	L1	L2	Code No.
20	205	110	195	TA20/2
25	230	120	215	TA25/2
40	270	125	295	TA40/2

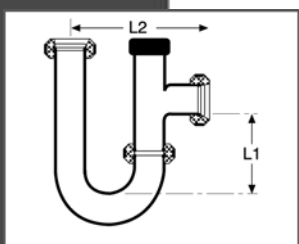

P Trap - Vertical Inlet / Horizontal Outlet

DN	L	L1	L2	Code No.
20	205	110	126	TA20/3
25	230	120	140	TA25/3
40	270	125	210	TA40/3

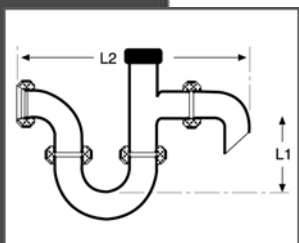

S Trap - Horizontal Inlet / Outlet

DN	L	L1	L2	Code No.
20	205	110	260	TA20/4
25	230	120	280	TA25/4
40	270	125	375	TA40/4

Scientific Glass Laboratories Ltd

t. 01782 816237 f. 01782 575637

Canal Lane, Tunstall, Stoke-on-Trent, Staffordshire ST6 4PQ
 email. sales@scientificglass.co.uk www.scientificglass.co.uk



Traps & Fittings

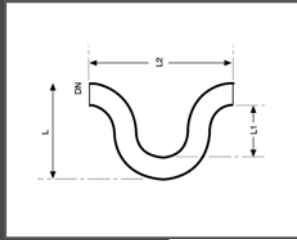

Fan Coil Trap - Horizontal Inlet / Outlet

DN	L	L1	L2	Code No.
20	95	50	165	TA20/F

Pipes & Fittings

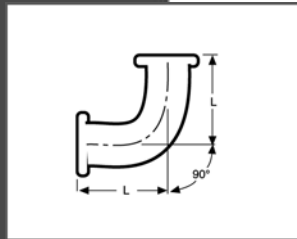

90° Bend

DN	L	Code No.
20	63	BB90-20
25	70	BB90-25
40	80	BB90-40

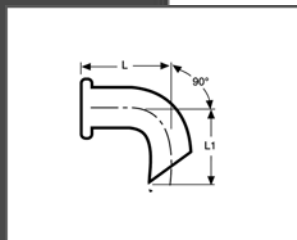

90° Discharge Bend

DN	L	Code No.
20	63	BD90-20
25	70	BD90-25
40	80	BD90-40

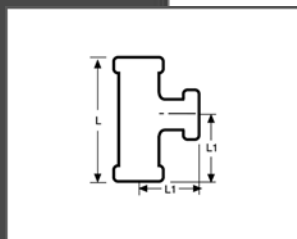

Equal 90° Tee Pieces

DN	L	L1	Code No.
20	126	63	ET90-20
25	140	70	ET90-25
40	160	80	ET90-40

Scientific Glass Laboratories Ltd

t. 01782 816237 f. 01782 575637

Canal Lane, Tunstall, Stoke-on-Trent, Staffordshire ST6 4PQ
 email. sales@scientificglass.co.uk www.scientificglass.co.uk



Pipes & Fittings

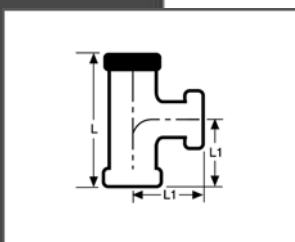

Equal 90° Tee Pieces with Screw Cap

DN	L	L1	Code No.
20	126	63	SC90-20
25	140	70	SC90-25
40	160	80	SC90-40

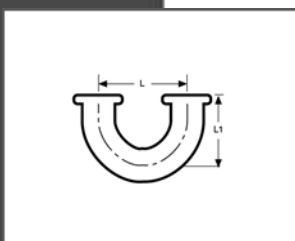

U Bend

DN	L	L1	Code No.
20	63	63	BU-20
25	70	70	BU-25
40	130	85	BU-40

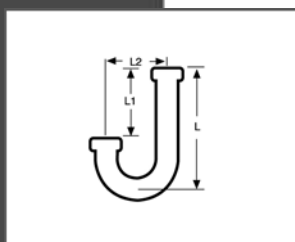

J Bend

DN	L	L1	L2	Code No.
20	175	100	63	BJ-20
25	185	100	70	BJ-25
40	200	95	130	BJ-40

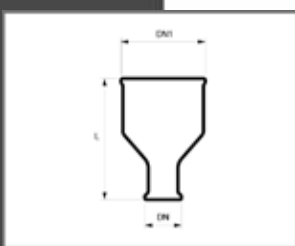

Glass Tundish / Drip Cup

DN	DN1	L	Code No.
20	75	100	DC20/75
25	75	100	Dc25/75
40	75	100	DC40/75
40	100	125	DC40/100

Scientific Glass Laboratories Ltd

t. 01782 816237 f. 01782 575637

Canal Lane, Tunstall, Stoke-on-Trent, Staffordshire ST6 4PQ
 email. sales@scientificglass.co.uk www.scientificglass.co.uk



Pipes & Fittings



Pipe Sections

DN	L	Cat Code
20	25	SGL-20-0025
20	50	SGL-20-0050
20	100	SGL-20-0100
20	250	SGL-20-0250
20	500	SGL-20-0500
25	25	SGL-25-0025
25	50	SGL-25-0050
25	100	SGL-25-0100
25	250	SGL-25-0250
25	500	SGL-25-0500
40	25	SGL-40-0025
40	50	SGL-40-0050
40	100	SGL-40-0100
40	250	SGL-40-0250
40	500	SGL-40-0500

Couplings



SGL's unique Coupling System provides confidence in bacterial control through experience in laboratory glass product design.

At the heart of the SGL system is a simple one-bolt coupling which is used to join components together, the PTFE (polytetrafluoroethylene) liner is the only part of the coupling that comes into contact with the condensate, thus, due to the unique inert properties of glass & PTFE seals the colonisation of bacteria is prevented.

As no heat or adhesives are required, SGL condensate systems are more than often installed quicker than any other services. This also allows for dismantling of the system in the same way.

Standard Couplings

DN	L1	L2	L3	Code N
20	40	54	22	BC-20
25	52	65	27	BC-25
40	70	80	35	BC-40

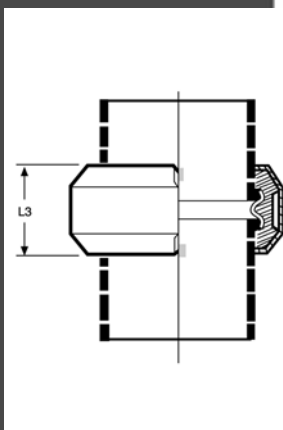
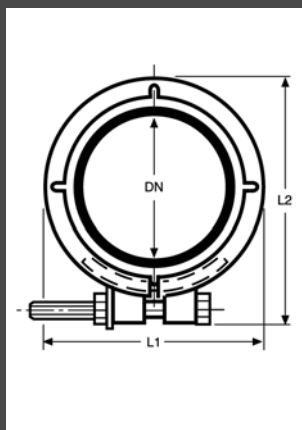
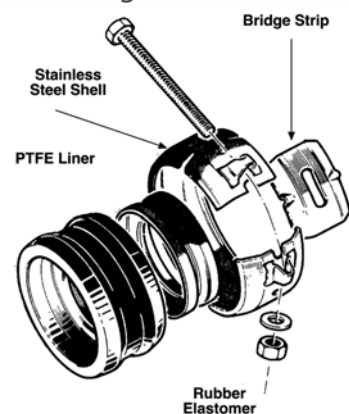

Scientific Glass Laboratories Ltd

t. 01782 816237 f. 01782 575637

Canal Lane, Tunstall, Stoke-on-Trent, Staffordshire ST6 4PQ
 email. sales@scientificglass.co.uk www.scientificglass.co.uk



Connections



PTFE Screwed Pipe Adaptors

DN	Internal Thread	Code No.
20	3/4" BSPT	BA-20
25	1" BSPT	BA-25
40	1 1/4" BSPT	BA-40A
40	1 1/2" BSPT	BA-40B

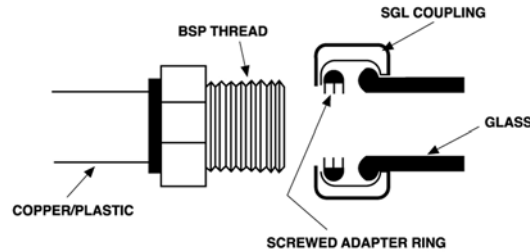

The easiest and most economical way of connecting to other materials is by utilising the standard BSP thread. As the majority of AHU manufacturers now fit BSP male threads to the drain pans as standard on their units, SGL have moved to make this its preferred method of connection: A simple 'O' ring - "BSP threaded adapter" is inserted into a standard glass/glass coupling, replicating the profile of the glass.

Sizing

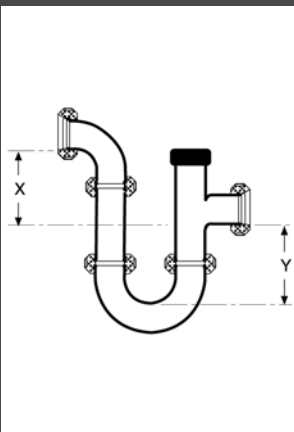
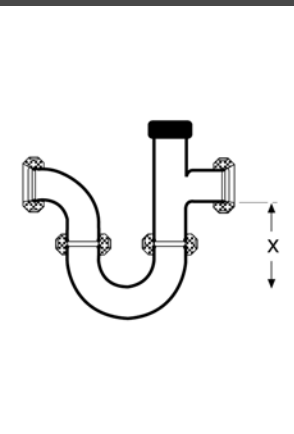

Correctly Sizing Seal Depths for SGL Glass Traps

Positive Side of Fan

$$\text{Seal Required (mm) "X"} = \frac{\text{Total Static Fan Pressure (Pascals)}}{5}$$

Negative Side of Fan

$$\text{Seal Required (mm) "X"} = \frac{\text{Total Static Fan Pressure (Pascals)}}{10}$$

"Y" dim should ideally be equal to "X" although 50% is acceptable
 n.b Formulae apply to all bore sizes of SGL Glass Traps

Scientific Glass Laboratories Ltd

t. 01782 816237 f. 01782 575637

Canal Lane, Tunstall, Stoke-on-Trent, Staffordshire ST6 4PQ
 email. sales@scientificglass.co.uk www.scientificglass.co.uk

